



# Micro & Maxi Stand

The ideal choice for ground-mounted support of all types of condensing units, mini-splits, VRV/VRF and heat pumps.

## KEY FEATURES ↓

- ✓ Suitable for all units.
- ✓ Adjustable length.
- ✓ Adjustable height.
- ✓ Max. load up to 450kg.

## PROPERTIES ↓

- ✓ Galvanised Frame
- ✓ Powder-coated in Black
- ✓ Temperature resistant -40 °C to +80 °C
- ✓ Quality assurance to ISO 9001 & ISO 14001

## OPTIONAL ADD-ONS ↓

- (Sold separately)
- ✓ Vibration dampers up to 450kg load.
  - ✓ Micro & Maxi tray support.

Description	Part No.
Micro Stand	<b>BN8410</b>
Maxi Stand	<b>BN8411</b>
Maxi Tray Support	<b>BN8412</b>
Micro Tray Support	<b>BN8413</b>
Tacco AVM 450kg (pack of 4)	<b>9898-040</b>

**BN8410**  
Micro Stand  
Weight: 11.5kg



**BN8411**  
Maxi Stand  
Weight: 16kg

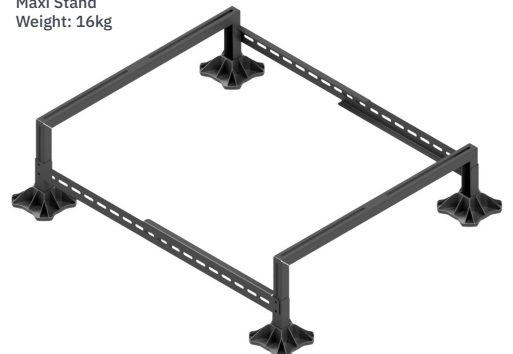

## OPTIONAL ADD-ONS ↓

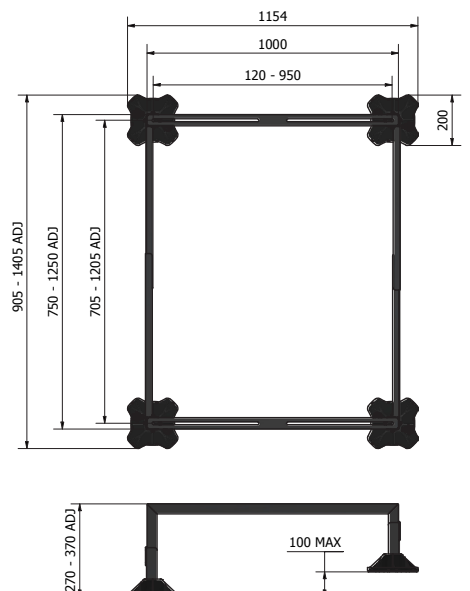
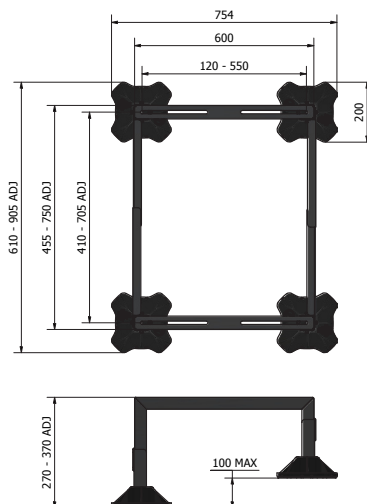
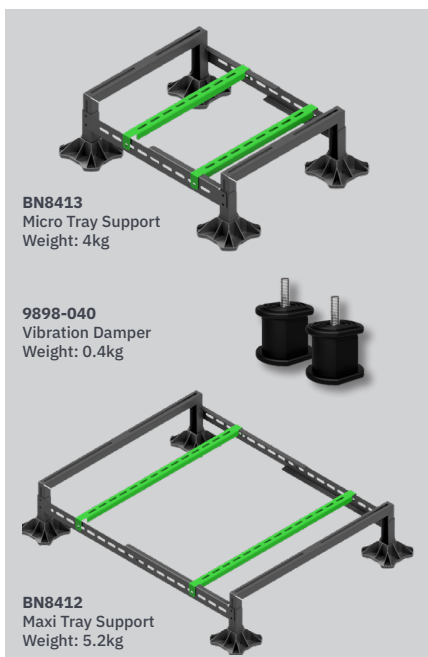

Information correct at time of going to press.